

# ELT series LoRa

LoRaWAN Wireless sensor

- ELT LoRa
- ELT Internal antenna LoRa
- ELT Lite LoRa



## ElektronikSystem i Umeå AB

Tvistevägen 48C  
907 36 Umeå  
Sweden

Phone: +4690100500  
E-mail: [info@elsys.se](mailto:info@elsys.se)  
Web: [www.elsys.se](http://www.elsys.se)

## Important safety information

**Read this manual before attempting to install the device!**



Failure to observe recommendations included in this manual may be dangerous or cause a violation of the law. The manufacturer, ElektronikSystem i Umeå AB will not be held responsible for any loss or damage resulting from not following the instructions of this operating manual.

- The device must not be dismantled or modified in any way.
- The device is only intended for indoor use. Do not expose it to moisture.

The device is not intended to be used as a reference sensor, and ElektronikSystem i Umeå AB will not be held liable for any damage which may result from inaccurate readings.

- The device must never be subjected to shocks or impacts.
- To clean the device, wipe with a soft moistened cloth. Use another soft, dry cloth to wipe dry. Do not use any detergent or alcohol to clean the device.



**Disposal note in accordance with Waste from Electrical and Electronic Equipment (WEEE) Directive 2012/19/EU**

The device, as well as all the individual parts, must not be disposed of with household waste or industrial waste. You are obliged to dispose of the device at the end of its service life in accordance with the requirements of Directive 2012/19/EU to protect the environment and to reduce waste through recycling. For additional information and how to carry out disposal, please contact the certified disposal service providers.

## Table of Contents

1.1 Description.....	4
1.2 ELT Series LoRa Attributes .....	4
1.3 Label.....	5
1.4 Dimensions.....	5
1.5 Main features of the ELT Series LoRa .....	6
2.1 Mounting Guidelines .....	7
3.1 Installation .....	7
3.2 Service and Maintenance.....	8
4.1 Sensor Configuration.....	8
4.2 NFC Configuration .....	8
4.3 Over the Air Configuration.....	9
4.4 Application Parameters .....	9
5.1 Sensor Startup.....	9
5.2 Sampling mode / Periodic measurement.....	9
5.3 Scheduled Transmission .....	9
5.4 LED Indication.....	9
6.1 Temperature .....	10
6.2 Humidity .....	11
6.3 Atmospheric Pressure.....	12
6.4 Accelerometer .....	12
7 External Sensors .....	13
8 Modules.....	13
9 Device Specifications .....	14
10 Sensor Payload Format .....	15
11.1 Legal Notices.....	15
11.2 Federal Communication Commission Interference Statement.....	15
11.3 Declaration of Conformity .....	17

# 1 Product Information

## 1.1 Description

The ELT series LoRa of sensors are universal LoRaWAN® industrial sensors for both in- and outdoor use. The internal sensors measure, depending on model, temperature, humidity, atmospheric pressure, and acceleration. The ELT series LoRa are also equipped with multi-purpose I/O for connection to external sensors and equipment.

The sensors are equipped with NFC (Near Field Communication) for easy configuration with an NFC-enabled smartphone.

## 1.2 ELT Series LoRa Attributes

Attribute	ELT Lite LoRa	ELT Internal antenna LoRa	ELT LoRa
Temperature		✓	✓
Humidity		✓	✓
Atmospheric pressure		✓	✓
Accelerometer		✓	✓
Multi-purpose I/O 1	✓	✓	✓
Multi-purpose I/O 2		✓	✓
Internal antenna		✓	
External antenna	✓		✓
NFC	✓	✓	✓

### 1.3 Label

At the back of your device there is a label with an Aztec barcode containing DevEUI and sensor type.

### 1.4 Dimensions

*Measurements are given in millimeters.*

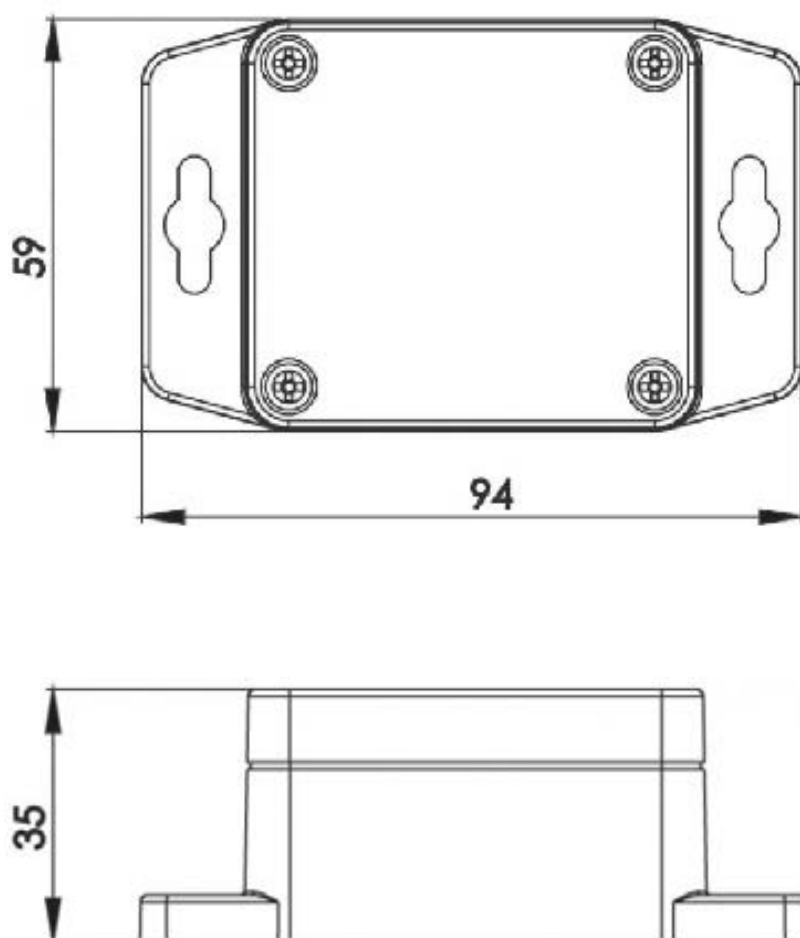

## 1.5 Main features of the ELT Series LoRa

- Compatible with LoRaWAN® specification 1.0.3
- IP67-rated
- Measures ambient temperature<sup>i</sup>
- Measures ambient humidity<sup>1</sup>
- Measures atmospheric pressure<sup>1</sup>
- Measures acceleration<sup>1</sup>
- Multi-purpose I/O<sup>ii</sup>
- Modular build with expandable functionality
- Can be connected to external sensors and meters
- Easy installation
- Easy configuration
- Battery-powered
- Long-range communication
- Configurable over NFC
- Configurable over the air
- Ten years of battery life<sup>1</sup>
- Supported channel plans: EU863-870, IN865, US902-928, AU915-928, AS923, KR920-923, HK923
- CE Approved and RoHS compliant
- FCC and ISED compliant variant on request

---

<sup>1</sup>Depending on model

<sup>2</sup>Number of multi-purpose I/O ports differ depending on model

<sup>3</sup>Depending on settings and environmental factors

## 2 Mounting Guidelines

### 2.1 Mounting Guidelines

Common mounting guidelines for ELT line of sensors:

- For best RF and measurement performance, make sure you mount the sensor with the antenna vertically. See installation in chapter 2.
- If external wiring is to be connected to the sensor and the sensor is to be placed in environments where it may get wet, consider water runoff and place the sensor with the cable gland placed vertically.
- Make sure that the sensor is not placed in direct sunlight, as the temperature reading from within the sensor case may be affected.

## 3 Installation

### 3.1 Installation

1. Remove the front lid.
2. Install the battery. The ELT requires one AA battery. The battery type is 3.6V Lithium Battery (ER14505). *Caution: Using batteries other than the ones provided may result in loss of performance, battery life, and also damage to the device. Dispose of properly observing environmental protection rules.*

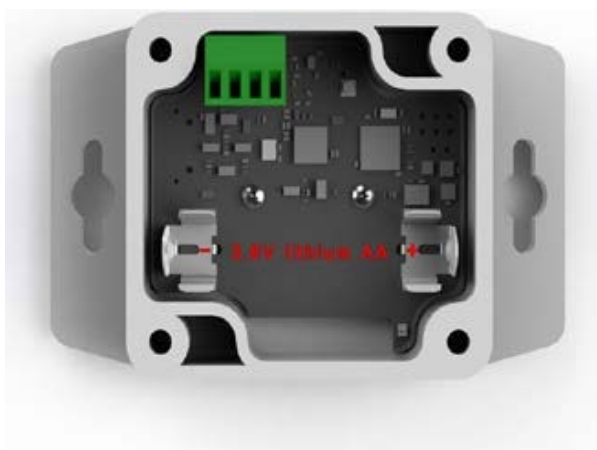

3. Screw the lid in place with the four provided screws.
4. Use screws or double-sided tape to mount the sensor on a surface.

## 3.2 Service and Maintenance

No serviceable parts inside. If service is needed other than battery replacement, please contact your distributor.

# 4 Sensor Configuration

## 4.1 Sensor Configuration

All sensor settings can be configured via a smartphone application with NFC (Near Field Communication) or over the air via the network server and downlink data to the sensor. The sampling rate, spreading factor, encryption keys, port, and modes can be changed. All sensor settings can be locked from the server or NFC to make end-users unable to read or change settings on the sensor.

## 4.2 NFC Configuration

1. Download ELSYS "Sensor Settings" application from Google Play or App store and install it on a smart phone or tablet. The device must support NFC.
2. Enable NFC on the device and start the application.
3. Place your device on top of the NFC antenna on the sensor. Keep the two devices close to each other and don't move them to get as good connectivity as possible.
4. Remove the device. Current settings will be displayed in the application.
5. Use the application to change any settings if needed.
6. Tap the device on top of the NFC antenna to transfer the new settings to the sensor. Make sure that the application confirms your new settings.
7. Wait for the sensor to reboot (1 sec), indicated by the LED flashing. Sensor settings have been updated. Always validate your settings by reading the NFC data after the sensor has restarted.



## 4.3 Over the Air Configuration

All settings may be configured over the air via your LoRaWAN® infrastructure. Please visit the support section on our webpage for more information regarding downlink protocol.

## 4.4 Application Parameters

All parameters for the “Sensor settings” application can be found in our settings document. Please visit the support section on our webpage for more information.

# 5 Sensor Behavior

## 5.1 Sensor Startup

1. When the sensor starts up it loads any configuration parameters written to the NFC chip. The sensor will then write all configuration parameters back to the NFC chip.
2. When the configuration is done the sensor tries to join the network if OTAA (Over the Air Activation) is enabled. Make sure that the sensor credentials (DevEUI, AppKey, JoinEUI) match the keys added in the server for activation of the device. The join procedure starts at spreading factor 7 with a join request every ~15 seconds. The sensor will gradually increase the time as well as the Spreading Factor between the following join requests until the join is successful. Every join request is indicated by a yellow LED blink.
3. After successful connection to a network, the sensor sends an uplink containing the sensor settings and enters sampling mode.

## 5.2 Sampling mode / Periodic measurement

The sensor makes periodic measurements according to the user configuration.

## 5.3 Scheduled Transmission

The sensor transmits data according to the user configuration. However, the configured sending interval can be overridden by network limitations. Due to this, the spreading factor and sending interval settings might result in longer intervals than intended.

## 5.4 LED Indication

The LED, located in the bottom right corner on the PCB, indicates different actions when the sensor is active.

LED Indicator	Action
Long Red blink, long Green blink	Sensor is starting up
Short Yellow Blink	LoRa Join Request Transmission
Short Green Blink	LoRa Uplink Transmission
Short Red Blink	Sensor failed to send an uplink. Common cause is duty cycle limits.

## 6 Internal Sensors

The populated internal sensors in the ELT series LoRa differ between models according to the list below.

Attribute	ELT Lite LoRa	ELT Internal antenna LoRa	ELT LoRa
Temperature		✓	✓
Humidity		✓	✓
Atmospheric pressure		✓	✓
Accelerometer		✓	✓
Multi-purpose I/O 1 (IN)	✓	✓	✓
Multi-purpose I/O 2 (I/O2)		✓	✓

### 6.1 Temperature

Resolution	0.1 °C
Accuracy	0.2 °C typical, see figure 7

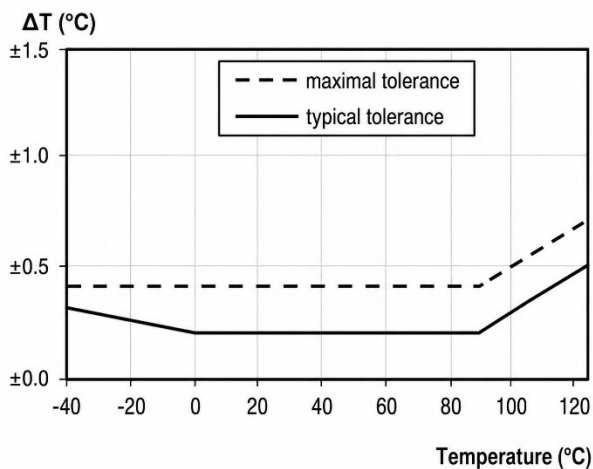

Figure 7. Temperature accuracy.

## 6.2 Humidity

Note that the internal sensor will react very slowly to external changes in humidity. The humidity sensor can be somewhat helped by equipping the ELT with a membrane if cable gland is not needed, but the response time will not be comparable to a sensor exposed to open air.

Resolution	1 % RH
Accuracy at 25 °C	±2 % RH, see figure 8

For accuracy of RH over temperature, see figure 9

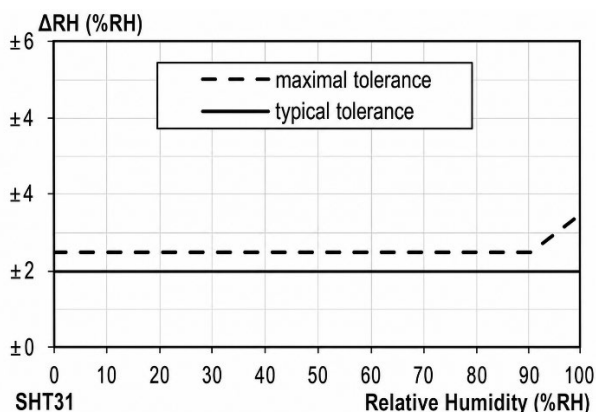

Figure 8. Tolerance of RH at 25°C.

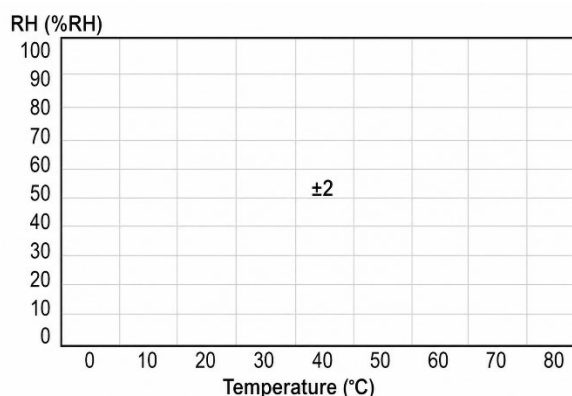

Figure 9. Typical tolerance of RH over T.

## 6.3 Atmospheric Pressure

Note that the ELT LoRa is equipped with a cable gland with a pressure membrane, which allows for atmospheric pressure reading while keeping its IP 67 rating.

Range	260 - 1260 hPa
Accuracy	± 1 hPa

## 6.4 Accelerometer

The accelerometer sensor reports values of X, Y and Z direction, depending on the sensor orientation. The accelerometer can be configured to send triggered messages when the measured acceleration exceeded a threshold in any axis for a selected amount

Range	± 2.0 g
Sensitivity	16 mg/digit
Data rate	10 Hz

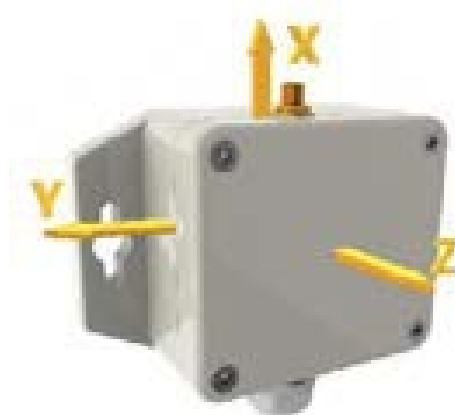

## 7 External Sensors

The ELT series LoRa of sensors can be connected to a wide array of external sensors, equipment, and modules. All connections to external gear are made available through the terminal block located on the top left of the circuit board inside the ELT. Available connections on the terminal block are power, ground and either one or two multi-purpose I/O-ports depending on the ELT variant.

*For external sensor configuration, wiring diagrams, supported sensor types, and all related parameters, refer to the **External Sensor Configuration Guide** document, available in the support section on our webpage.*

## 8 Modules

ELSYS provides modules for the ELT LoRa that fit in the terminal block and expands the functionality of the ELT. Available modules are:

**EXT Module:** When the EXT Module is installed, the ELT LoRa can be externally powered and be used as a LoRaWAN class C or a class A device. Add this to the ELT LoRa to control external sensors such as lighting or actuators/relays. It can also be set to output 0-10V voltage.

**ADC Module:** ADC Module is intended for connecting PT1000 platinum sensors or to be used as a general-purpose bridge amplifier. Install the ADC Module in the ELT LoRa to be able to measure temperatures with PT1000 or connect a load cell bridge.

**Dual PT-1000 Module:** An alternate ADC module designed for two PT1000 temperature probes to be connected simultaneously. *Note: Requires firmware version 2.4.6 or later.*

**Step-up Module:** The Step-up module is a boost converter for the ELT LoRa. It boosts the internal battery voltage to 5V at the connector, making it suitable for powering sensors with a supply voltage demand of 5V. The I/O connections are unaffected.

## 9 Device Specifications

Dimensions	94 x 59 x 35 mm
Weight	60g / 97g (with battery inserted) / 70 - 95 g including batteries
Enclosure	Polycarbonate
IP Rating	IP67
Mounting	Screws/Adhesive tape
Recommended installation height	Wall: 1.6 m
Usage Environment	Indoor/Outdoor
Temperature	-40 to 60 °C (85 °C with external power supply)
Operating Voltage	3.6 V DC
Battery Type	AA 14505 (3.6V Li-SOCI2)
Battery Life	Up to 10 years (Depending on settings and environmental factors)
Wireless Technology	LoRaWAN® 1.0.3
Wireless Security	LoRaWAN® End-to-End encryption (AES-CTR), Data Integrity Protection (AES-CMAC)
LoRaWAN® Device Type	Can be configured as class A, B or C end device
Supported LoRaWAN® regions	EU868, IN865, US915, AU915, AS923, HK923, KR923
Supported LoRaWAN® features	OTAA, ABP, ADR, Adaptive Channel Setup
Link Budget	137dB (SF7) to 151 dB (SF12)
RF Transmit Power	Max 14 dBm EIRP
EU Directives Compliance	RED 2014/53/EU, RoHS 2011/65/EU, WEEE 2012/19/EU

## 10 Sensor Payload format

The device uses the standard ELSYS payload format. Please see the specified document on our webpage.

## 11 Regulations

### 11.1 Legal Notices

All information, including, but not limited to, information regarding the features, functionality, and/or other product specification, are subject to change without notice. ELSYS reserves all rights to revise or update its products, software, or documentation without any obligation to notify any individual or entity. ELSYS and ELSYS logo are trademarks of ElektronikSystem i Umeå AB. All other brands and product names referred to herein are trademarks of their respective holders.

### 11.2 Federal Communication Commission Interference Statement

(Pending. Estimated 24/04/01)

This device complies with Part 15 of the FCC Rules and with Industry Canada licence-exempt RSS standard(s). Operation is subject to the following two conditions:

- (1) this device may not cause harmful interference, and
- (2) this device must accept any interference received, including interference that may cause undesired operation.

Le présent appareil est conforme aux CNR d'Industrie Canada applicables aux appareils radio exempts de licence. L'exploitation est autorisée aux deux conditions suivantes:

- (1) l'appareil ne doit pas produire de brouillage, et
- (2) l'appareil doit accepter tout brouillage radioélectrique subi, même si le brouillage est susceptible d'en compromettre le fonctionnement.

#### **Radiofrequency radiation exposure Information:**

This equipment complies with FCC and Innovation, Science and Economic Development radiation exposure limits set forth for an uncontrolled environment. This equipment should be installed and operated with minimum distance of 20 cm between the radiator and your body. This transmitter must not be co-located or operating in conjunction with any other antenna or transmitter.

### Informations sur l'exposition aux rayonnements radiofréquences:

Cet équipement est conforme à la réglementation de la FCC et aux limites d'exposition aux rayonnements définies par Innovation, Sciences et Développement économique pour un environnement non contrôlé. Cet équipement doit être installé et utilisé à une distance minimale de 20 cm entre le radiateur et votre corps. Cet émetteur ne doit pas être co-localisé ou fonctionner en conjonction avec une autre antenne ou un autre émetteur.

#### Note

Changes or modifications made to this equipment not expressly approved by ElektronikSystem i Umeå AB may void the FCC authorization to operate this equipment.

#### Notice

This equipment has been tested and found to comply with the limits for a Class B digital device, pursuant to Part 15 of the FCC Rules. These limits are designed to provide reasonable protection against harmful interference in a residential installation. This equipment generates, uses and can radiate radio frequency energy and, if not installed and used in accordance with the instructions, may cause harmful interference to radio communications. However, there is no guarantee that interference will not occur in a particular installation. If this equipment does cause harmful interference to radio or television reception, which can be determined by turning the equipment off and on, the user is encouraged to try to correct the interference by one or more of the following measures:

- Reorient or relocate the receiving antenna.
- Increase the separation between the equipment and receiver.
- Connect the equipment into an outlet on a circuit different from that to which the receiver is connected.
- Consult the dealer or an experienced radio/TV technician for help.

FCC ID	IC ID
2ANX3-ELT01	26904-ELT01

## 11.3 Declaration of Conformity

Hereby, ElektronikSystem i Umeå AB declares that the radio equipment type "Radio communication devices for low-speed data R&TTE Class 1" is in compliance with Directive 2014/53/EU, Directive 2011/65/EU and Directive 2012/19/EU.

The full text of the EU declaration of conformity is available at:

<https://www.elsys.se/en/documents-firmware>

## 12 Revision History

Revision	Description	Date
1.0	ELT Series operating manual created	2024-02-27
1.1	Name change	2025-04-29
1.2	Removed Ultrasonic models and internal ultrasonic sensors. External sensor details moved to the External Sensor Configuration Guide.	2026-06-23

---

<sup>1</sup>Depending on model

<sup>2</sup>Number of multi-purpose I/O ports differ depending on model

### ElektronikSystem i Umeå AB

Tvistevägen 48C  
907 36 Umeå  
Sweden

Phone: +4690100500  
E-mail: [info@elsys.se](mailto:info@elsys.se)  
Web: [www.elsys.se](http://www.elsys.se)